

ProPak Thermal 55-Series DS Semi Instantaneous Packaged Plate Heat Exchanger

Product Description

WRAS and KIWA UK Reg 4 Approved Packaged Plate Heat Exchanger suitable for Domestic Hot Water Generation.

The ProPak Thermal range of packaged plate heat exchangers are suitable for the generation of domestic hot water in commercial and industrial applications. Each WRAS and KIWA UK Reg 4 approved unit is constructed with Stainless Steel AISI 316 plate heat exchangers, has a MODBUS interface and ERP A rated primary pumps.

ProPak ® Thermal Range: Features

- Full WRAS Approval (WRAS Approval Number 2312347)
- Heat outputs: 75 – 800kw
- Stainless Steel AISI 316 Plates
- EPDM Gaskets
- ERP A rated Primary Pumps
- PID Controller with MODBUS Interface
- Fast acting Siemens 3-port valve
- High Density, Semi-Rigid Insulation

ProPak ® Thermal Range: Options

- Skid Mounting with pre-connected Buffer Vessel
- High Outputs: 1mw + options

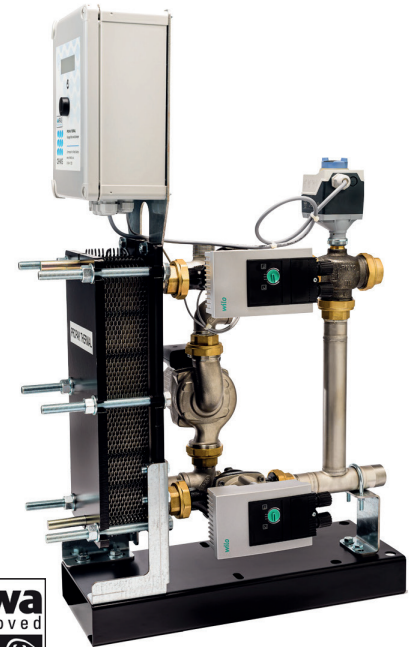

Technical Specification

Plate Construction Material	AISI 316L Stainless Steel
Gasket Construction Material	EPDM - PRX Gasket
Press Plate and Mounting Frame Construction Material	Epoxy Coated Quality Mild Steel
Ancillaries Mounting Pipework	AISI 316L Stainless Steel
Insulating Jacket Material	30mm High Density Semi - Rigid Polyolefin Foam (PO)
Full PID Control Unit	MODBUS RTU/RS 485 BMS Interface
Maximum Full Load Current	10 Amp
Primary Circuit Motorised 3 Port Control Valve	Siemens VXF 32.50-40 / SAX 619.03 Actuator
Primary Circulation Pump(s)	WILO YONOS PARA HF 50/12
Secondary Circuit Shunt Pump	Grundfos TP 50 - 60
Total Height	1685 mm
Total Length	1013 mm
Total Width	786 mm
Weight	272 kg
Maximum Operating Pressure - Primary	10 bar
Maximum Operating Pressure - Secondary	10 bar
WRAS Approval Number	2312347

ProPak Thermal 55-Series DS Semi Instantaneous Packaged Plate Heat Exchanger

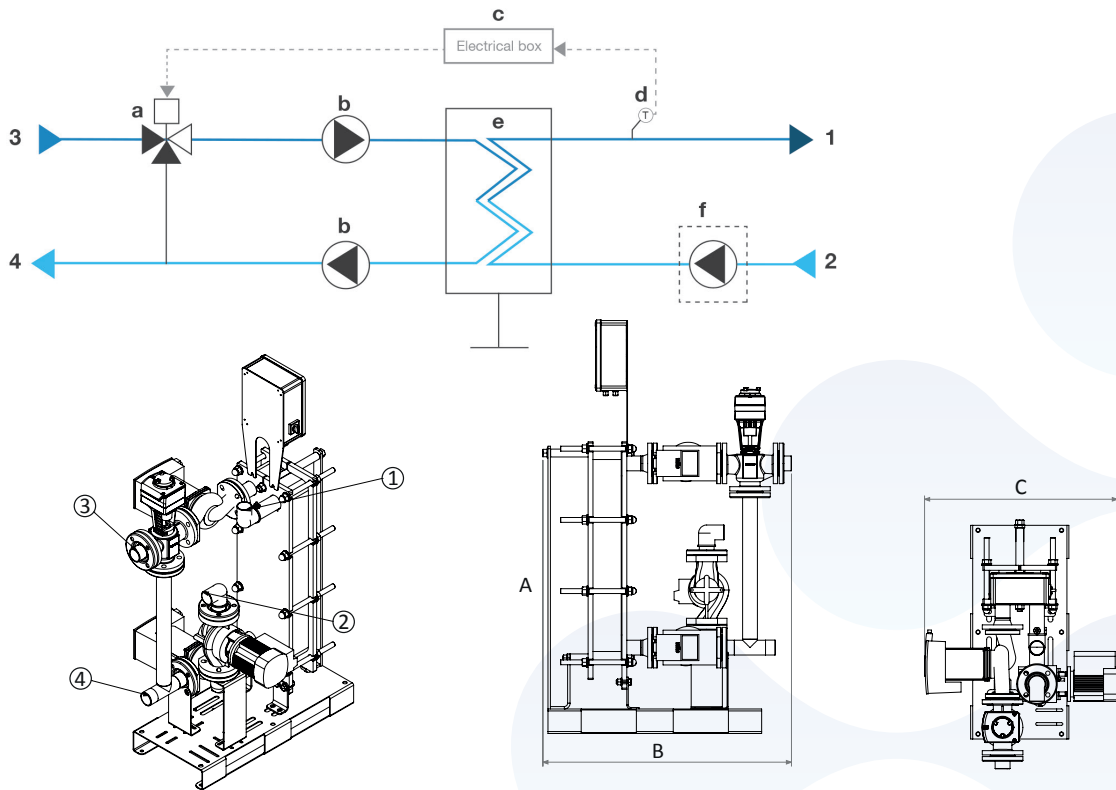

Dimensions (mm)

A	1685
B	1013
C	786

Connections

1	Secondary Outlet Connection - DN50
2	Secondary Inlet Connection - DN50
3	Primary Inlet Connection - DN50
4	Primary Outlet Connection - DN50

Schematic Drawing Key

a	Motorised 3 Port Control Valve
b	Primary Circulation Pump(s)
c	PID Control Unit - MODBUS / BMS Interface
d	Control Temperature Sensor - PT1000
e	Gasketed Plate Heat Exchanger
f	Secondary Circulation Pump



ProPak Thermal Packaged Plate Heat Exchanger

Project Name:	
Date Created:	
Recommended Model:	

Primary Flow & Return Temp @

°C/ °C

Heat Load Required / Max Duty	kW
DHW Flow Rate/Hour ΔT 50°C	litres
Secondary Circuit Flow Rate	l/s
Secondary Pressure Drop (Peak)	kPa
Primary Circuit Flow Rate	l/s
Primary Pressure Drop (Peak)	kPa
Primary Circuit Fluid	Water

Recommended Clearances:

Propak Clearances

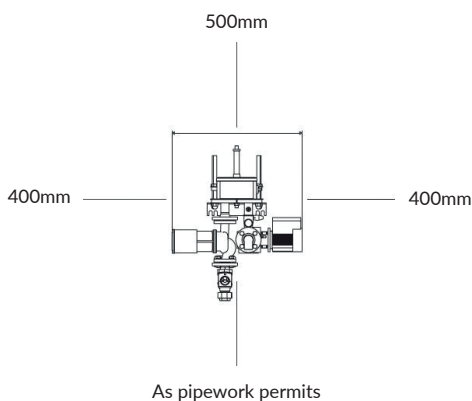

Water Quality

In hard water areas, suitable water conditioning or water softening should be installed to the cold-water supply to prevent equipment failure due to hard scale build-up.

Products will not be covered under warranty for failure due to poor water quality, limescale build-up or corrosion due to aggressive soft water.

If in doubt the installer should contact a water quality expert to discuss. In all instances, products should be installed and maintained as per the CHWS product O&M manual.

Warranty

The unit is covered by a 2 year warranty. If the water quality deviates from the parameters outlined above the product cannot be covered by warranty.

