

ProRapid 800

Semi Instantaneous DHW Generator

Product Description

The ProRapid range of Semi Instantaneous DHW Generators are suitable for a wide range of water heating applications. Each ProRapid unit combines a AISI 316 stainless steel DHW buffer vessel with externally mounted WRAS approved brazed plate heat exchanger, charging pump and control panel. The ProRapid is suitable for use with a variety of primary heat sources including Gas Boilers, District Heating Schemes and Heat Pumps.

ProRapid Range: Features

- BMS Compatible
- Integral Legionella Control
- Visual DHW Temperature Display
- High Temperature Thermostat
- Option for Single or Three Phase Electrical Immersion Elements



**ASHP
READY**



Technical Specification

Capacity	883 litres
Orientation	Vertical
Construction Material: Shell	AISI 316L Stainless Steel
Construction Material: Plate Heat Exchanger	Stainless Steel WRAS No: 2011003
Charging Pump	WILO STAR Z 20/7: WRAS No: 2106803
Insulation Material & Thickness	100mm Flexible Polyurethane with metal sheet outer
Standing Energy Losses*	105 w/hr
	2.52 kwh/24hrs
Total Height with Insulation	2110mm
Total Diameter	1000mm
Total Diameter + PHX Assembly	1300mm
Weight Empty	178 kg
Maximum working pressure - Vessel	6 bar
Test Pressure	9 bar
Maximum working temperature	99°C

* Based upon ERP standard 65°C cylinder temperature at 20°C ambient air temperature

ProRapid 800 Semi Instantaneous DHW Generator

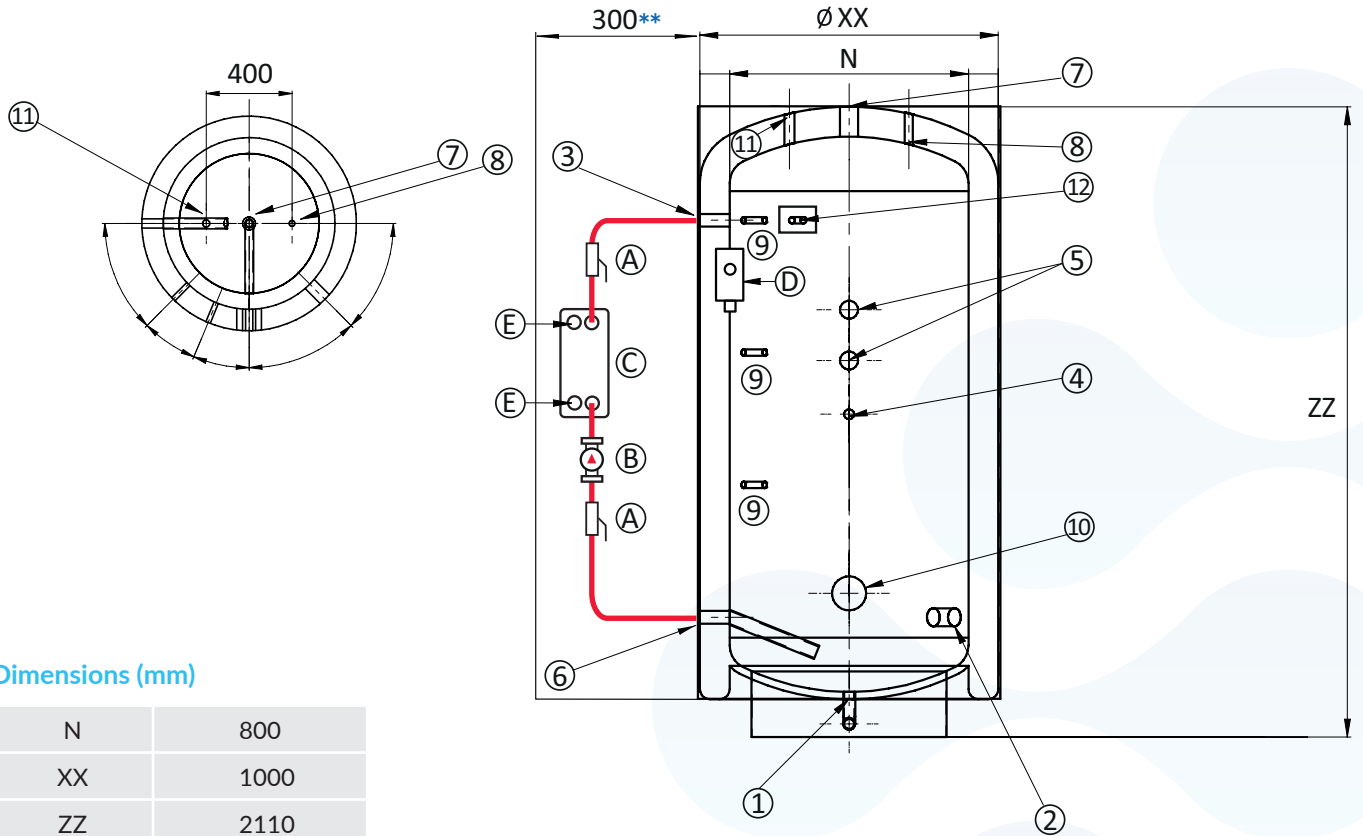

Dimensions (mm)

N	800
XX	1000
ZZ	2110

Connections

1	Drain	1"
2	Service Connection	2"
3	Destratification Outlet	1 ¼"
4	Secondary Return Inlet	1"
5	Service Connection Optional Immersion	2"
6	Destratification Inlet	1 ¼"
7	Domestic Hot Water Outlet	2"
8	Temp & Pressure Relief Valve	¾"
9	Sensor Tappings x3	½"
10	Access Hatch / Electrical Immersion	4"
11	Anti Vac Valve	1"
12	High Limit Stat	½"

A	Isolation Valve
B	Charging Pump
C	Brazed Plate Heat Exchanger
D	Control Panel
E	Primary Connections: PHE 1"/1 ¼" *

* Primary connection size depends upon kw heat input and temperature profile.

** Approximate dimension depending upon PHE design.

