

| Cylinder Connections Key | | |
|--------------------------|---------------------|---|
| Number | Size | Description |
| 1 | 1, 1/4" (Female) | ProRapid Flow Connection Point |
| 2 | 1, 1/4" (Female) | ProRapid Return Connection Point |
| 3 | 1/2" BSP (Female) | Sensor Pocket for ProRapid Sensor 1 |
| 4 | 1/2" BSP (Female) | Sensor Pocket (Spare/BMS/Other...) |
| 5 | 1/2" BSP (Female) | Sensor Pocket (Spare/BMS/Other...) |
| 6 | 1/2" BSP (Female) | Sensor Pocket for ProRapid Sensor 2 |
| 7 | 1/2" BSP (Female) | Connection for ProRapid High Limit Thermostat |
| 8 | 2" BSP (Female) | Connection for (Optional) Immersion Heater |
| 9 | 1" BSP (Female) | (Optional Location) Connection for Hot Water Services (HWS) Secondary Return Pipe |
| 10 | 2" BSP (Female) | Connection for (Optional) Immersion Heater |
| 11 | 4" BSP (Female) | Maintenance Inspection point |
| 12 | 2" BSP (Female) | Connection for Cold Water Services (CWS/BCWS) Inlet Pipe |
| 13 | 1" BSP (Female) | Drain Point |
| 14 | 1 1/2" BSP (Female) | Connection for Automatic Air Vent or other Ancillary connection (not supplied) |
| 15 | 2 1/2" BSP (Female) | Connection for Hot Water Services (HWS) Outlet Pipe |
| 16 | 1 1/2" BSP (Female) | Temperature and Pressure Relief Valve (T&P) (Supplied) |



Commercial Hot Water Solutions Ltd.
 71 -72 Gazelle Road
 Weston Industrial Estate
 Weston-super-Mare
 Somerset
 BS24 9ES
 01934 244770

THIS DRAWING AND ITS CONTENTS ARE PROPERTY
 OF CHWS LTD. DO NOT DISCLOSE, REPRODUCE, OR
 PUBLISH WITHOUT WRITTEN CHWS APPROVAL

| | | | | | | | |
|---------|----|-----------------------|------------|----------------------|--------|----------|---|
| DRAWN | GP | DATE | 10.03.2025 | DO NOT SCALE DRAWING | | REVISION | A |
| CHECKED | PR | APPROX PRODUCT WEIGHT | 368 kg | SCALE | 1 / 10 | | |

TITLE
XMF BUFFER TANK 2500 LT

DRAWING NUMBER
CHWS/XMF/2500/A

A3

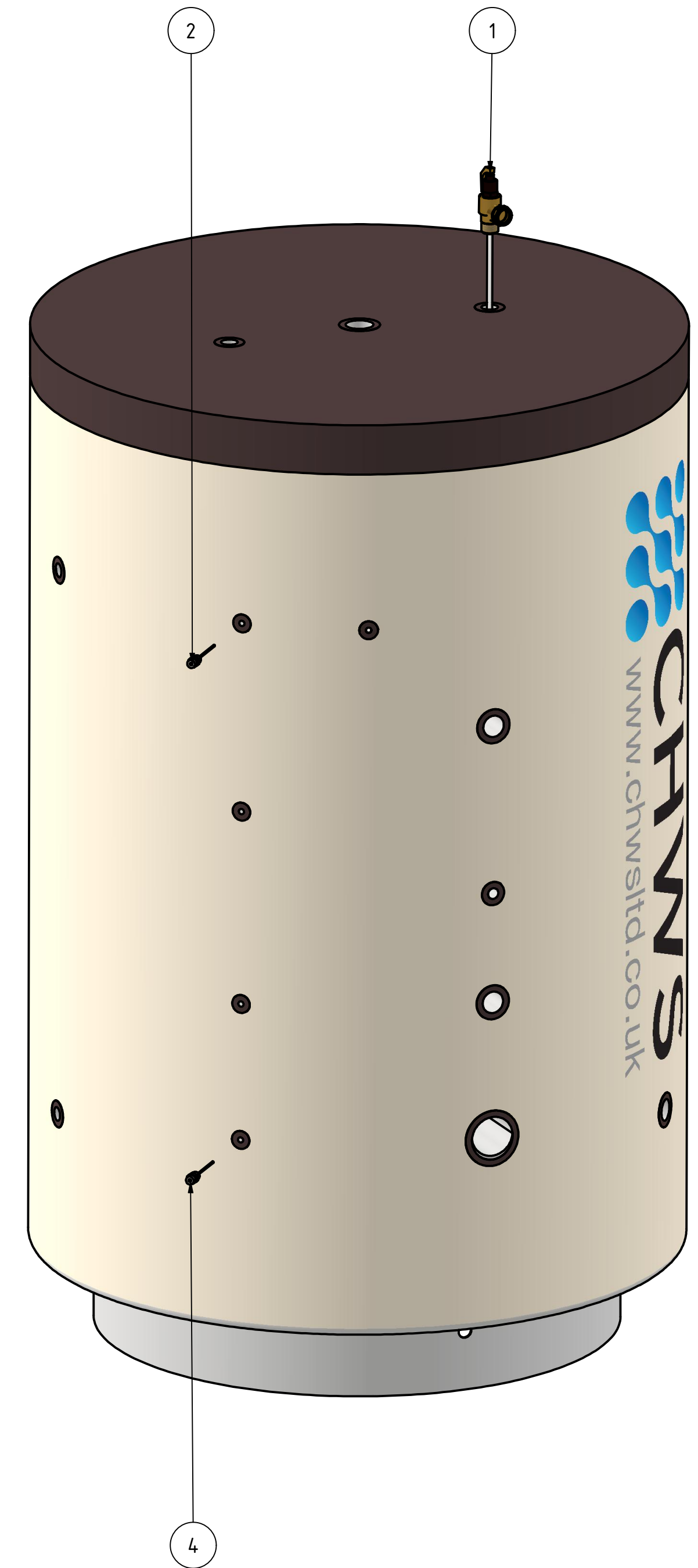
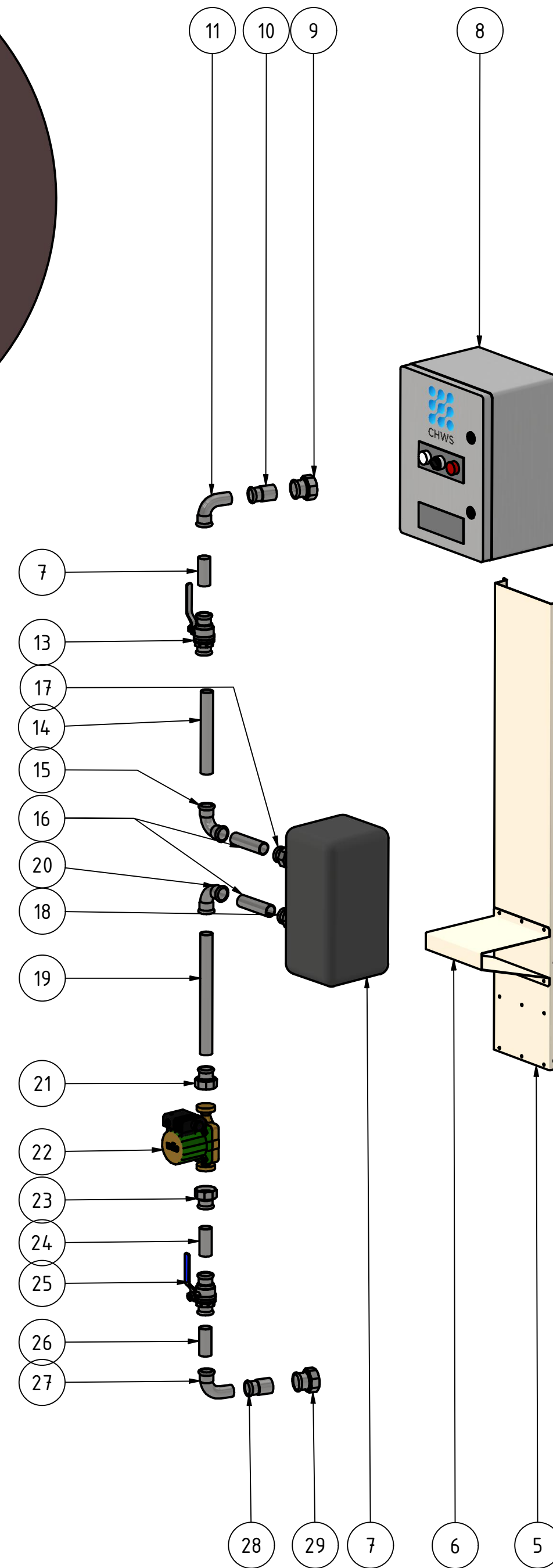
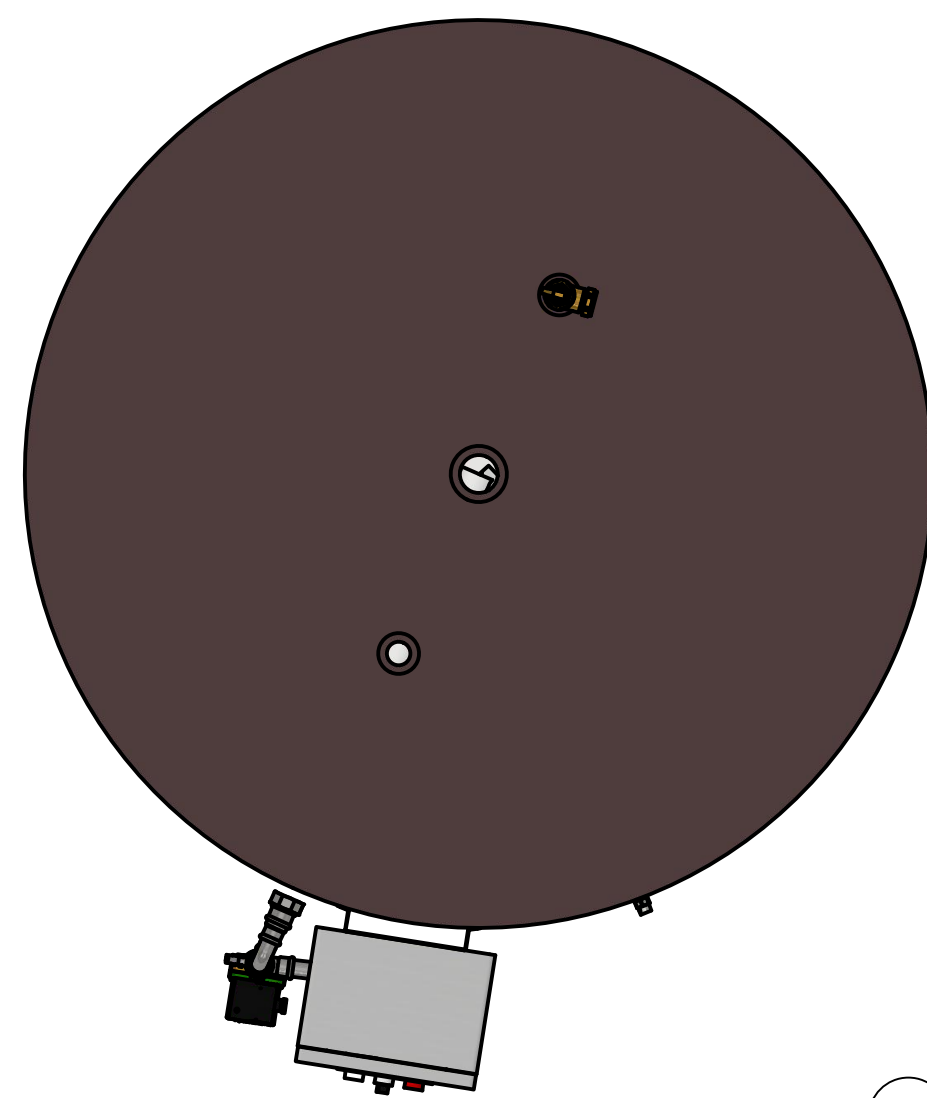
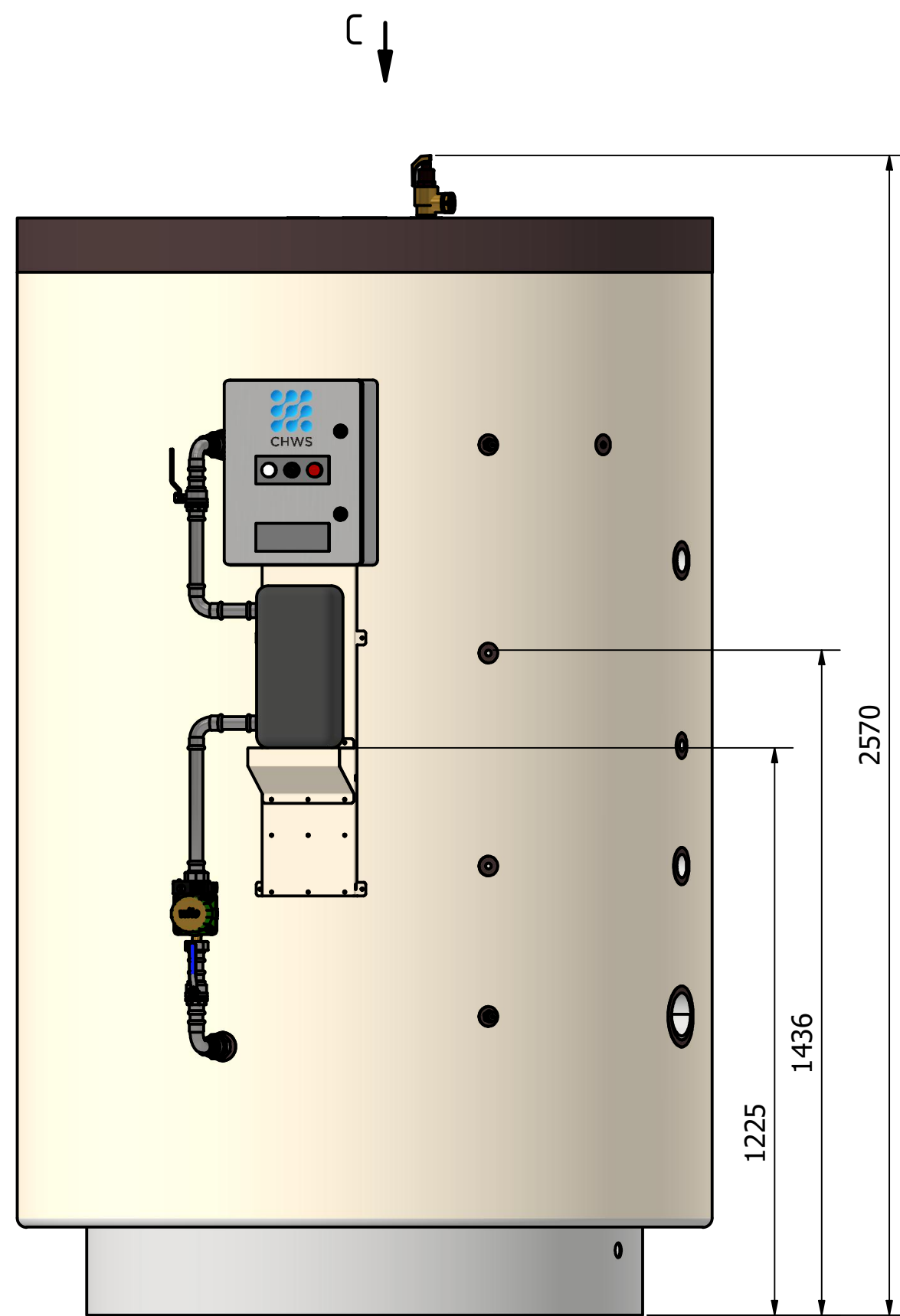
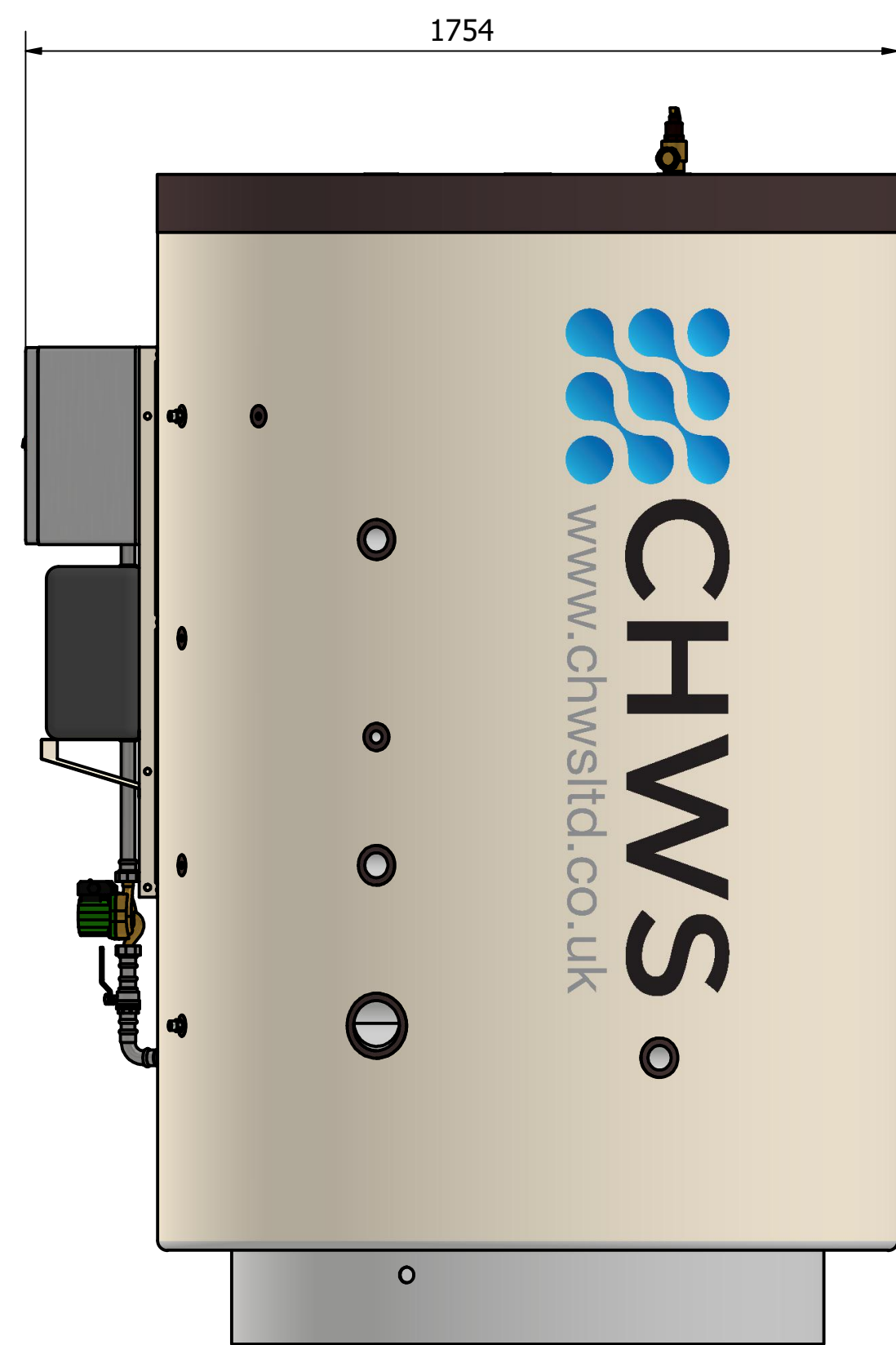

| Cylinder Connections Key | | | Cylinder Connections Key | | |
|--------------------------|-----------------------------------|--|--------------------------|----------------------------|---|
| Number | Size | Description | Number | Size | Description |
| 1 | 1 1/4" BSP Male inlet 22mm Outlet | Combined Temperature & Pressure Relief Valve (T&P) | 16 | 28mm | Copper Pipe |
| 2 | 1/2" BSP Male | Temperature Sensor Pocket for Sensor 1 | 17 | 28mm x 1" or 28mm x 1,1/4" | Pressfit Union (size depends on plate heat exchanger model) |
| 3 | 1/2" BSP Male | High Limit Thermostat | 18 | 28mm x 1" or 28mm x 1,1/4" | Pressfit Union (size depends on plate heat exchanger model) |
| 4 | 1/2" BSP Male | Temperature Sensor Pocket for Sensor 1 | 19 | 28mm | Copper Pipe |
| 5 | N/A | ProRapid Support Bracket | 20 | 28mm | Pressfit Bend |
| 6 | N/A | ProRapid Heat Exchanger Shelf | 21 | 28mm x 1,1/4" | Pressfit Pump Union |
| 7 | 1" or 1,1/4" connections | ProRapid Heat Exchanger (Models can Vary) | 22 | 1,1/4" | Wilo Star Z 20/7 - 3 Bronze Pump (150mm Face to Face) |
| 8 | (W) 300mm (D) 220mm (H) 400mm | ProRapid FW14 Control Panel | 23 | 28mm x 1,1/4" | Pressfit Pump Union |
| 9 | 1,1/4" x 35mm | Male BSP x Pressfit union | 24 | 28mm | Copper Pipe |
| 10 | 35mm x 28mm | Pressfit Reducer | 25 | 28mm | Pressfit Isolation Valve (Blue Handle) |
| 11 | 28mm | Street Bend (M+F) | 26 | 28mm | Copper Pipe |
| 12 | 28mm | Copper Pipe | 27 | 28mm | Street Bend (M+F) |
| 13 | 28mm | Pressfit Isolation Valve (Red Handle) | 28 | 35mm x 28mm | Pressfit Reducer |
| 14 | 28mm | Copper Pipe | 29 | 1,1/4" x 35mm | Male BSP x Pressfit union |
| 15 | 28mm | Pressfit Bend | | | |

Note: All Pressfit fittings are "M" Profile



Commercial Hot Water Solutions Ltd.
 71 -72 Gazelle Road
 Weston Industrial Estate
 Weston-super-Mare
 Somerset
 BS24 9ES
 01934 244770

THIS DRAWING AND ITS CONTENTS ARE PROPERTY
 OF CHWS LTD. DO NOT DISCLOSE, REPRODUCE, OR
 PUBLISH WITHOUT WRITTEN CHWS APPROVAL

| | | | |
|---------|----|-----------------------|------------|
| DRAWN | GP | DATE | 10.03.2025 |
| CHECKED | PR | APPROX PRODUCT WEIGHT | 410 kg |

| | | | |
|---------------------------|--|----------|----|
| DO NOT SCALE DRAWING | | REVISION | A |
| TITLE | | | |
| CHWS 2500L ProRapid | | | |
| DRAWING NUMBER | | | A3 |
| CHWS/PRORAPID/2500/FW14/A | | | |
| SCALE | | 1 : 12.5 | |