

**ProStor BV 1500
DHW Buffer Storage Vessel**

Product Description

DHW Buffer Vessel with a WRAS approved Vitreous lining

The ProStor BV range of commercial domestic hot water buffer vessels are suitable for a wide range of water heating applications. Each vessel can be used in conjunction with a ProPak Thermal Packaged Plate Heat Exchanger, Electrical Immersion Heaters, or Removable Heat Exchangers. The vessel has a WRAS approved Vitreous lining to prevent corrosion.

BV Range: Features

- WRAS approved Vitreous Lining
- Capacities: 300 – 3000 litres
- Electrical Immersion Tapping
- De-stratification Tappings
- Flanged Inspection Hatch
- 100mm Insulation
- Low Standing Losses
- 3 Year Warranty

BV Range: Options

- Suitable for use with removable heat exchangers, electrical immersions or ProPak Thermal packaged plate heat exchangers
- De-stratification Pump
- Rockwool / Stucco Insulation



Technical Specification

Capacity	1430 litres	
Heat Input	via Removable Heat Exchanger or Plate Heat Exchanger	
Orientation	Vertical	
Construction Materials	High Quality Steel with WRAS Approved Vitreous Lining	
Insulation Material & Thickness	100mm Soft Polyurethane with PVC Outer Jacket	
Standing Energy Losses*	162 w/hr	
	3.89 kwh/24hrs	
Total Height with Insulation	2245mm	
Total Diameter with Insulation	1200mm	
Total Diameter without Insulation	1000mm	
Weight Empty	246 kg	
Maximum working pressure - Vessel	8 bar	
Test Pressure	12 bar	
Maximum working temperature	95°C	
Vitreous Lining WRAS Approval Number	Up to 1000 litres	1909560
	1500 litres +	1911521

* Based upon ERP standard 65°C cylinder temperature at 20°C ambient air temperature

ProStor BV 1500 DHW Buffer Storage Vessel

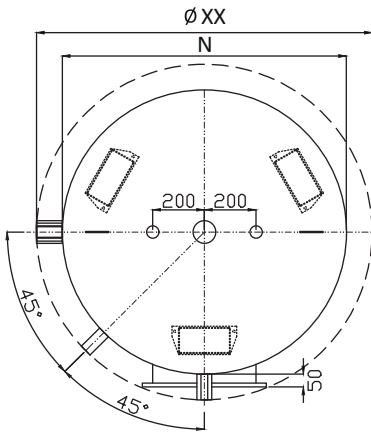

Dimensions (mm)

N	1000
XX	1200
ZZ	2245

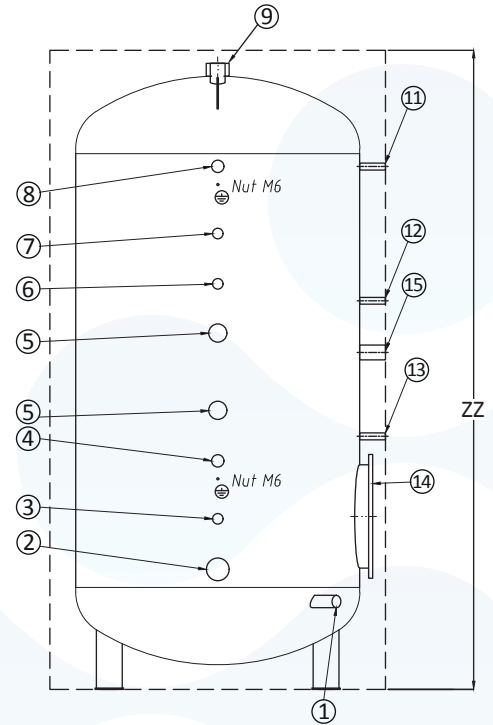
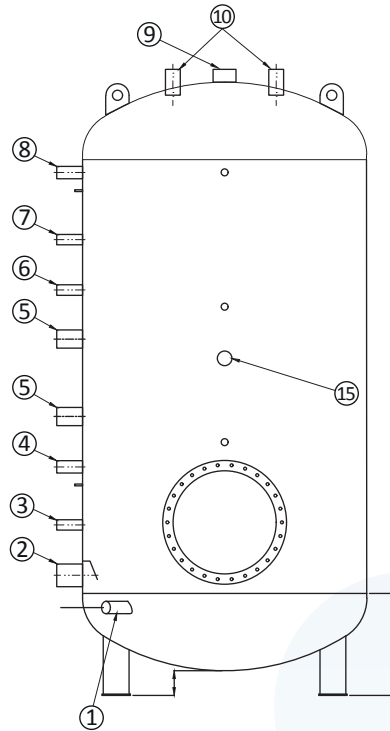

Connections

1	Drain	1 ¼"
2	Service Connection	2 ½"
3	Destratification Outlet	¾"
4	Sacrificial Anode	1 ¼"
5	Service Connection or Optional Immersion Heater	2 x 2"
6	HWS Secondary Return Inlet	1"
7	Destratification Inlet	¾"
8	Sacrificial Anode	1 ¼"
9	Domestic Hot Water Outlet	2 ½"
10	Temp & Pressure Relief Valves	1"
11	Hi - Limit Temperature Stat	½"
12	BMS Sensor Pocket	½"
13	BMS Sensor Pocket	½"
14	Flanged Inspection Access and Heat Exchanger Inlet	480 / 400mm
15	Electrical Resistance	1 ½"

Water Quality

In hard water areas, suitable water conditioning or softening equipment must be installed to treat the sanitary water prior to heating.

The water must have a conductivity of not less than 150 µS/cm and a hardness between 10°F and 20°F (equivalent to less than 1.00 mmol/litre of alkaline earth ions).

The chloride concentration must not exceed 70 mg/l, and the Langelier Saturation Index (LSI) at operating temperature should remain within the range of 0.0 to +0.4.

In all cases, water quality must be maintained within these parameters to ensure the protection and efficient operation of the system.

This is in addition to regular maintenance as outlined in our Operation / Installation Manual.

